



M12000 Premier

M12000 Premier

Product line for sliding frames with inox steel roller driver and both EPDM gasket and Hi-Fin brush sealing, based on a 45 mm sash.

Basic characteristics:



- √ 45mm sash width
- √ Inox steel roller driver for easier and smoother sliding (near zero friction).
- √ 32 mm heavy-load rollers, made of teflon.
- √ Perimetrical sealing with two rows of EPDM gaskets and two rows of Hi-Fin membrane brushes.
- √ Single or multiple point lock, with backset application inside the frame's sliding guide.
- √ Option of glazing installation as in conventional "tilt-and-turn" systems, using a sash with a complementary glazing bead.

TECHNICAL SPECIFICATIONS OF PROFILES	
Aluminum alloy	AlMgSi (EN AW 6063)
Hardness	12 Webster or 70 HB minimum
Minimum Powder Coating Thickness	75µm minimum
Profile thickness (min-max)	1,5 – 1,8 mm
Profile Geometry Control	EN DIN 12020-2 Compliant











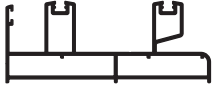

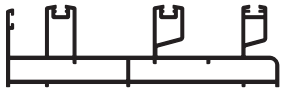
TECHNICAL SPECIFICATIONS OF SYSTEM TYPOLOGIES	
Sash Dimensions (Width \ Height)	45 / 82,3 mm
Sliding	32 mm teflon rollers on inox steel guide
Glazing type	Single or double, from 18 up to 32 mm
Maximum glazing weight	200 Kg
Sealing	Perimetrical, using two rows of EPDM gaskets and two rows of Hi-Fin brushes

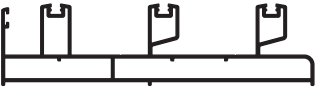

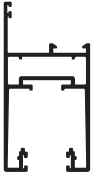

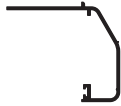
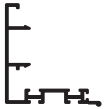
Product Line Construction Options:

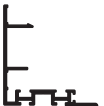
- √ Interlocking (with or without a fly-screen).
- √ Internal fusible (glazing or glazing with shutter or glazing with shutter and fly-screen)
- √ External fusible (glazing or glazing with shutter or glazing with shutter and fly-screen).

Certifications:

- √ The design, the production process, and the quality control of all profiles produced by Alumil are certified with ISO 9001.
- √ The process of electrostatic powder coating is certified by QUALICOAT and RAL (GSB) all plants operated by Alumil.

PROFILE	No/Profile No Weight (gr/m)	X mm Y mm	PROFILE	No/Profile No Weight (gr/m)	X mm Y mm
	M 12336 1763	108,10 41,00		M 12355 936	52,20 38,90
	M 12231 2241	143,90 40,90		M 9228 775	28,40 65,50
	M 12337 2602	165,10 41,00		M 14218 948	28,40 83,00
	M 12205 1352	45,00 89,30		M 14219 841	25,80 70,00
	M 12000 1388	45,00 87,50		M 6000 523	59,60 50,00
	M 12356 605	50,40 52,60		M 9416 411	48,30 50,00
	M 12363 641	49,70 52,90		M 11119 376	38,20 43,00

PROFILE	No/Profile No Weight (gr/m)	X mm Y mm
	M 11118 394	51,90 42,80
	M 777 332	46,10 38,70
	M 9312 266	19,30 21,70
	M 9311 304	18,90 21,80

M 12336

DOUBLE DRIVER

W=1763 gr/m

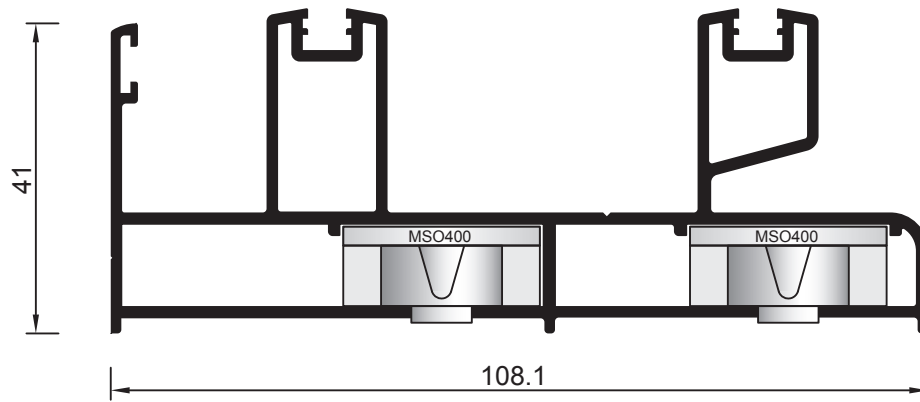

M 12231

DOUBLE DRIVER
WITH FLY SCREEN

W=2241 gr/m

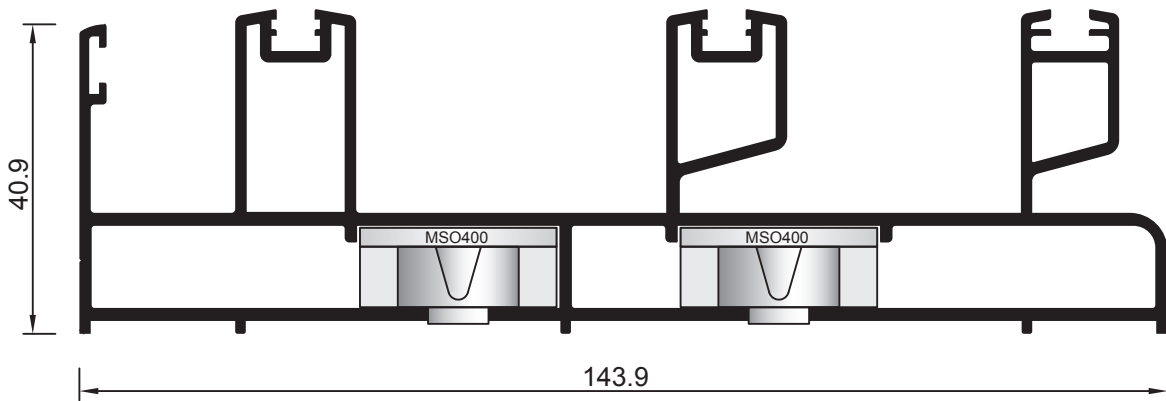

M 12337

TRIPLE DRIVER

W=2602 gr/m

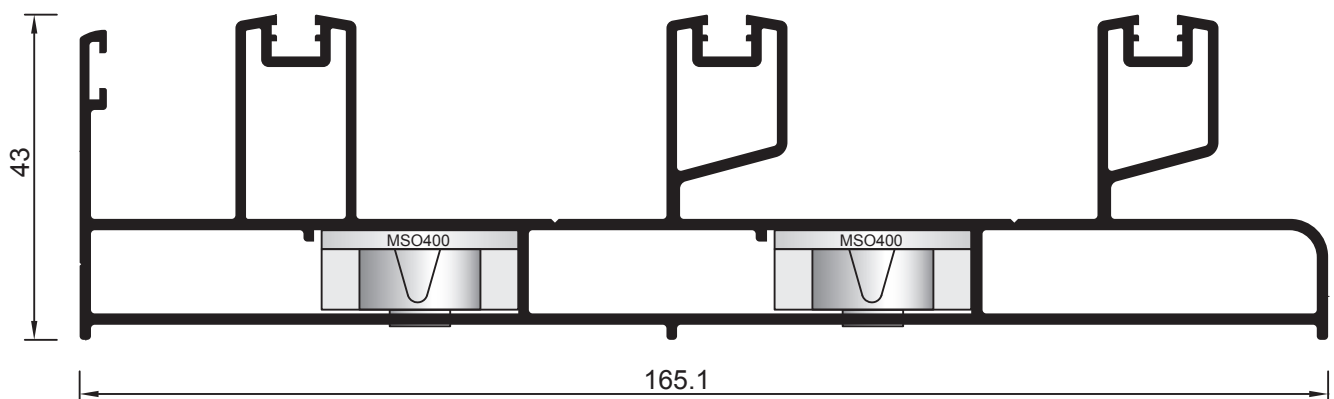

M 12205

W=1352 gr/m

Sash

Slide Only

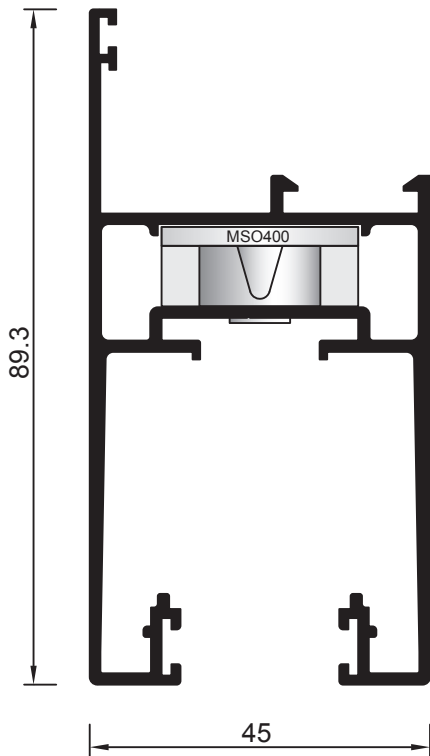

M 12000

W=1388 gr/m

Sash

Lift & Slide

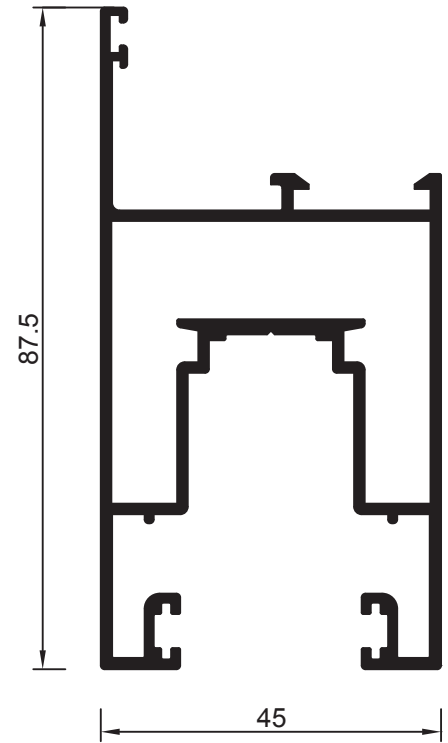

M 12356

W=605 gr/m

Hook

Slide Only

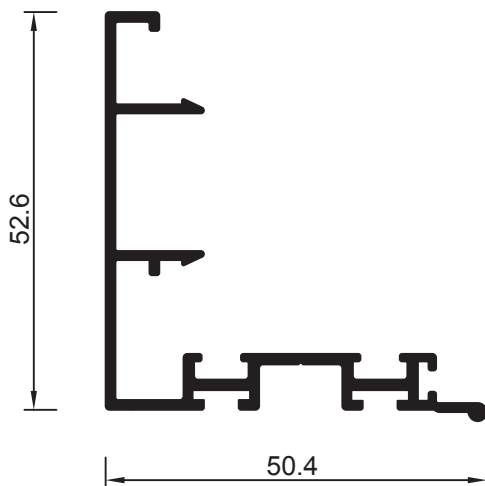

M 12363

W=641 gr/m

Hook

Lift & Slide

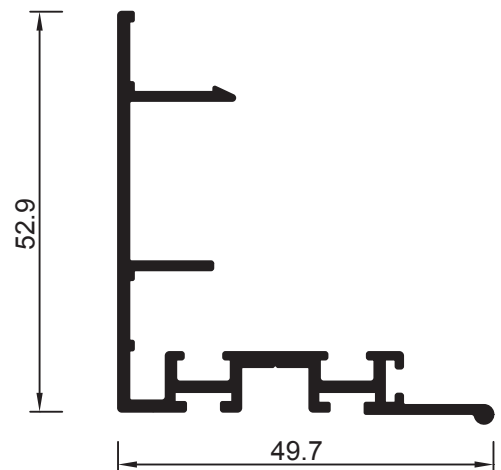

M 12355

W = 936 gr/m

**Adjoining
Slide Only**

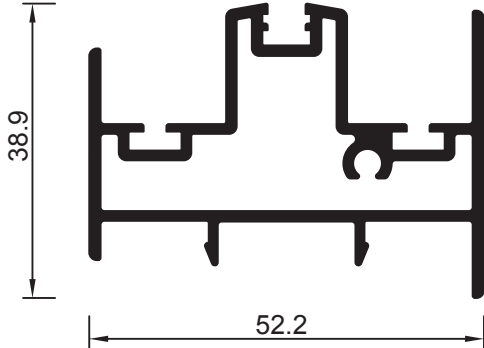

M 9228

W = 775 gr/m

**Fly Screen
Sash**

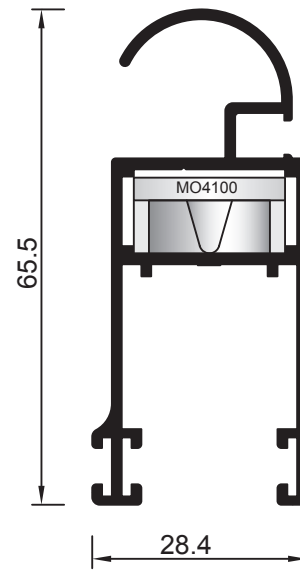

M 14218

W = 948 gr/m

**Fly Screen
Sash**

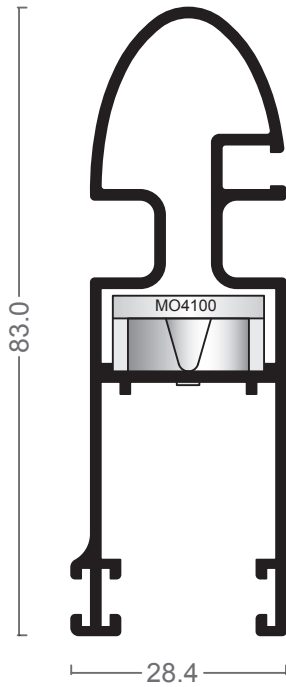

M 14219

W = 841 gr/m

**Fly Screen
Transom**

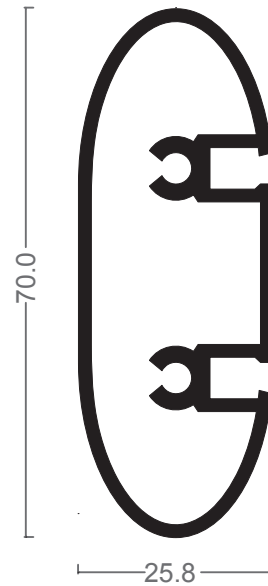

M 6000

W = 523 gr/m

Architrave

5 cm

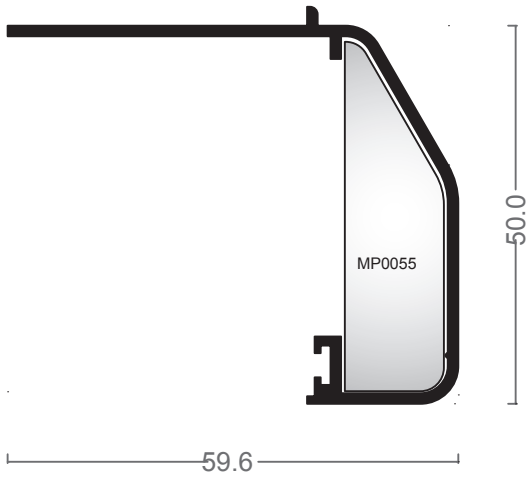

M 9416

W = 411 gr/m

Architrave

5 cm

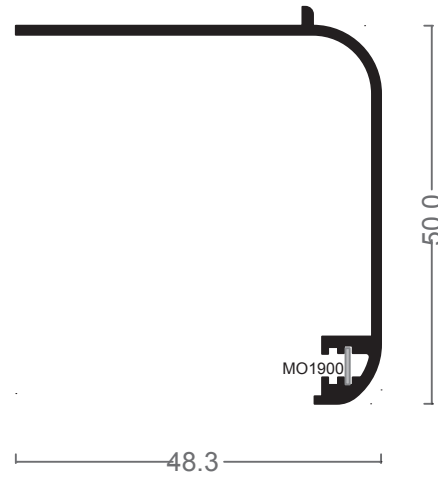

M 11119

W = 376 gr/m

Architrave

4 cm

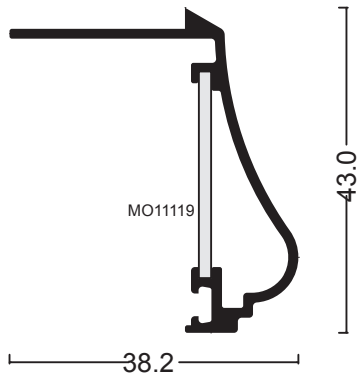

M 11118

W = 394 gr/m

Architrave

4 cm

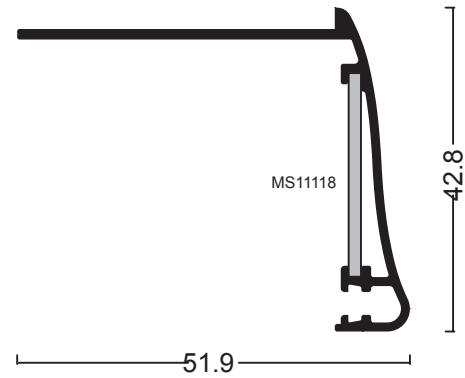

M 777

W = 332 gr/m

Architrave

3.5 cm

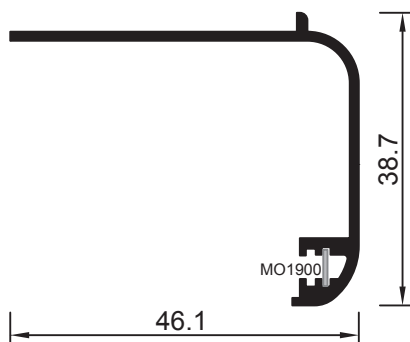

M 9312

W = 266 gr/m

**GLAZING BEAD
FOR DOUBLE GLAZING**

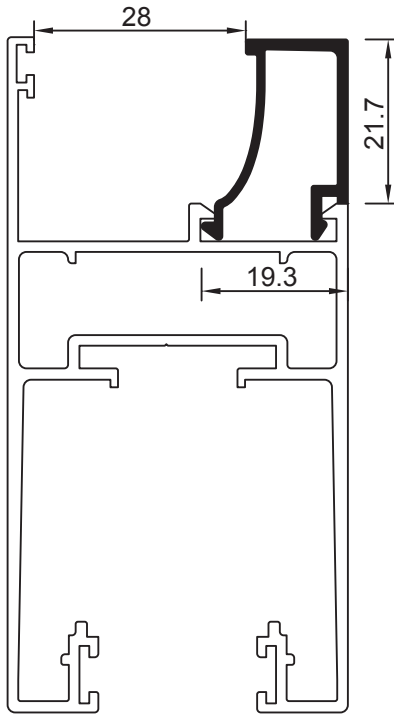

M 9311

W = 304 gr/m

**GLAZING BEAD
FOR SINGLE GLAZING**

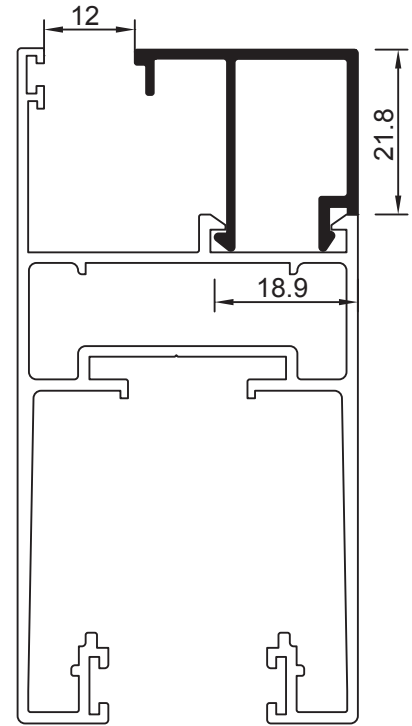

1)

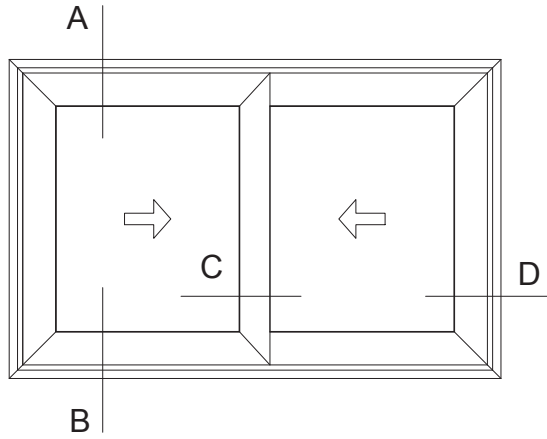

Section A

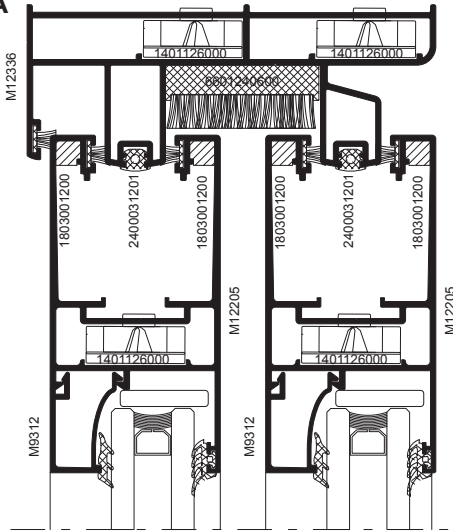

Section B

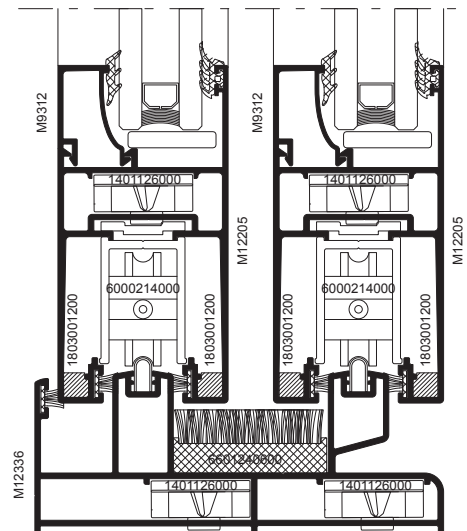

Section C

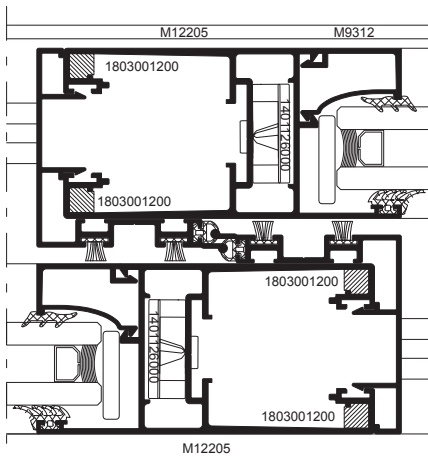

Section D

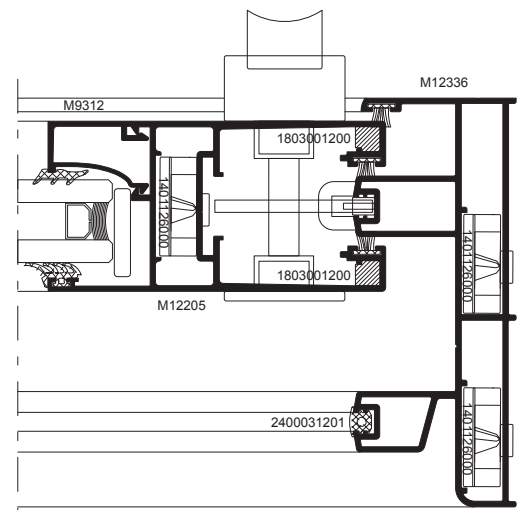

2)

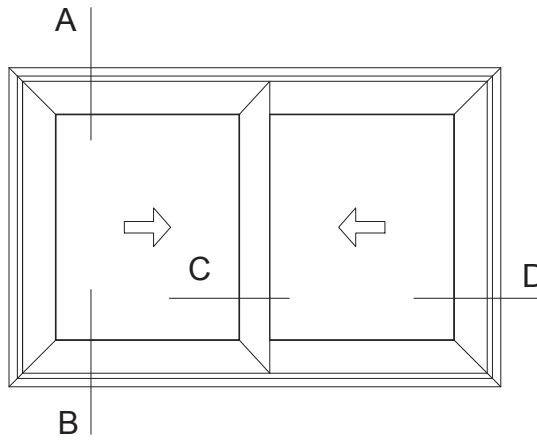

Section A

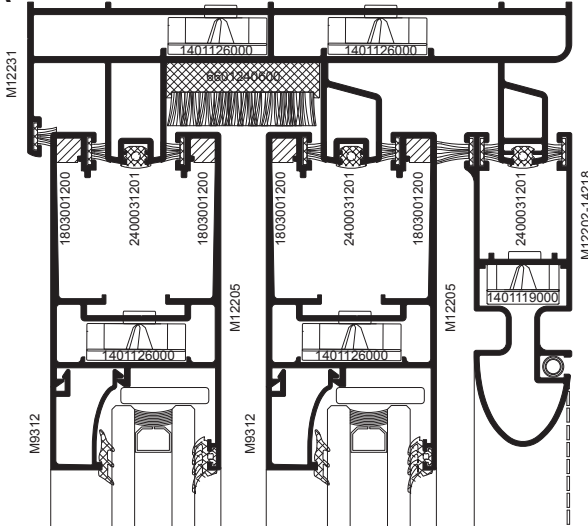

Section B

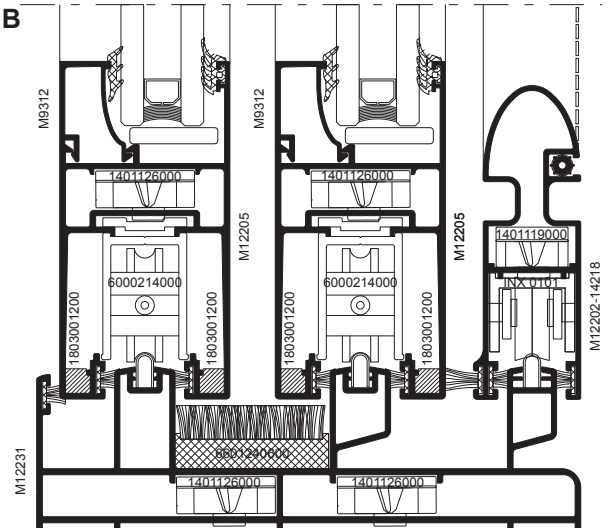

Section C

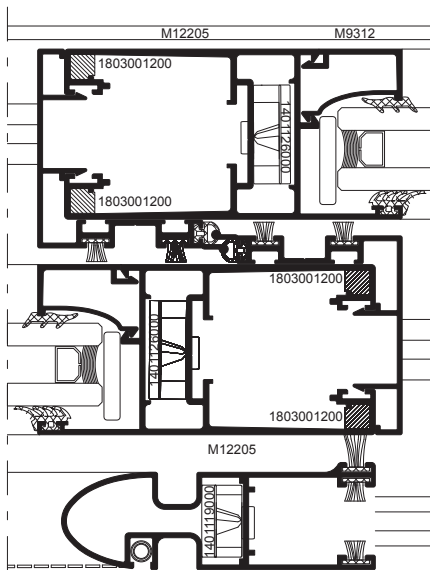

M12202-14218

Section D

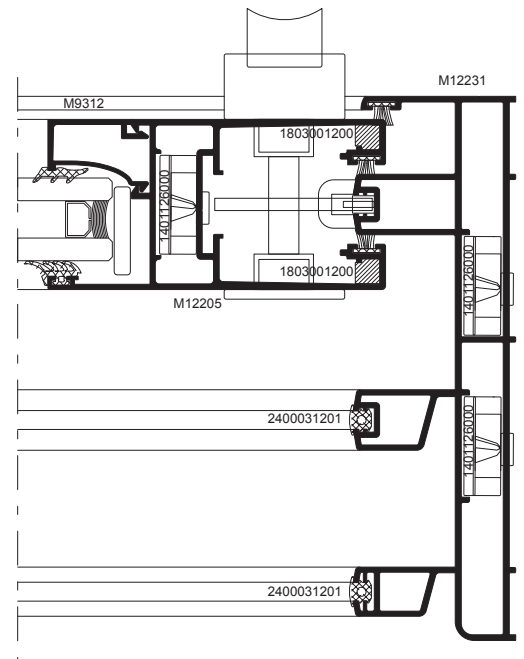

3)

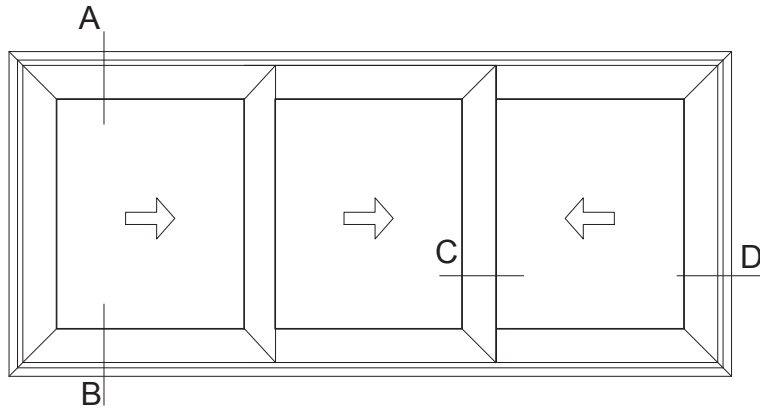

Section A

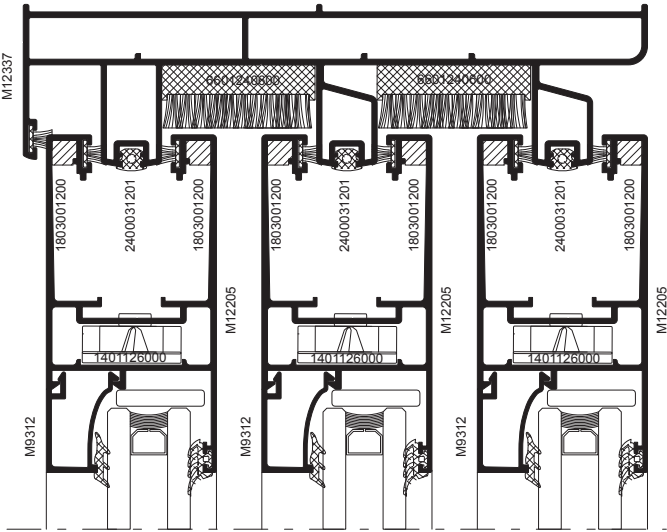

Section B

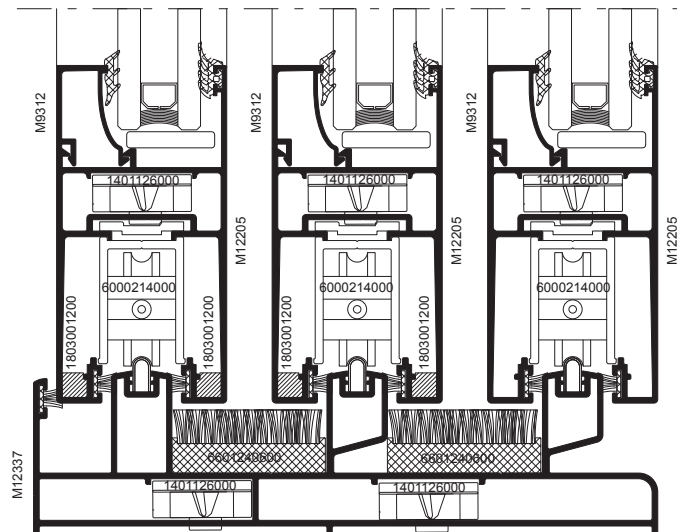

Section C

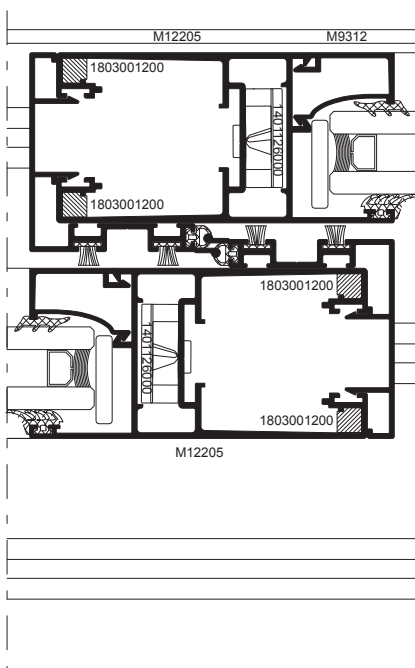

Section D

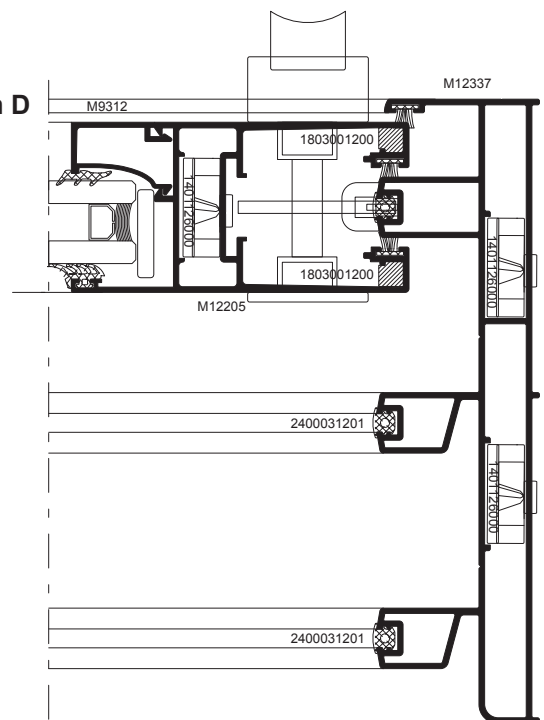

4)

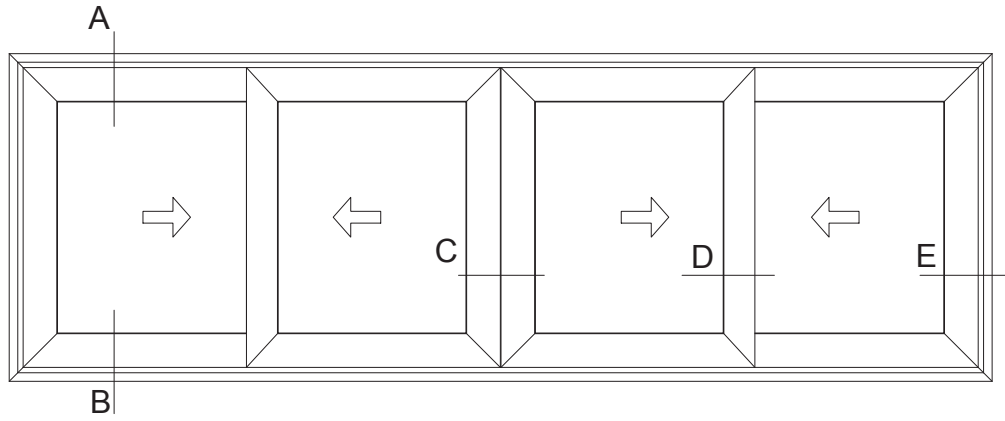

Section A

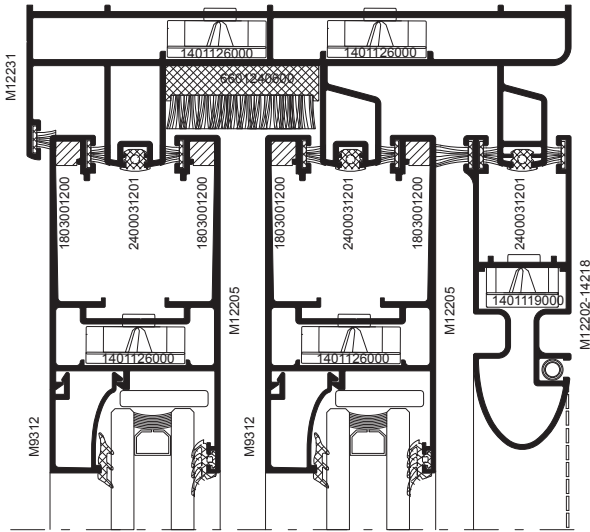

Section B

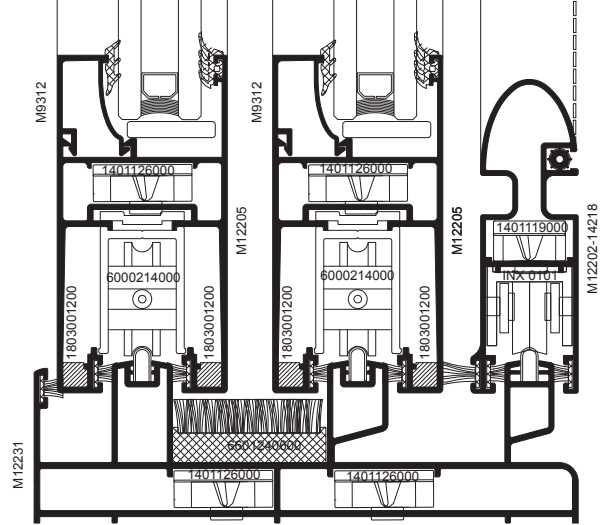

Section C

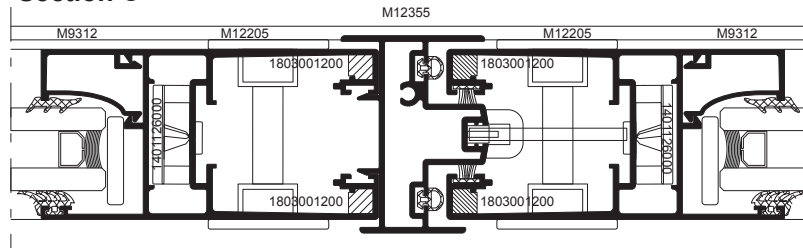

Section D

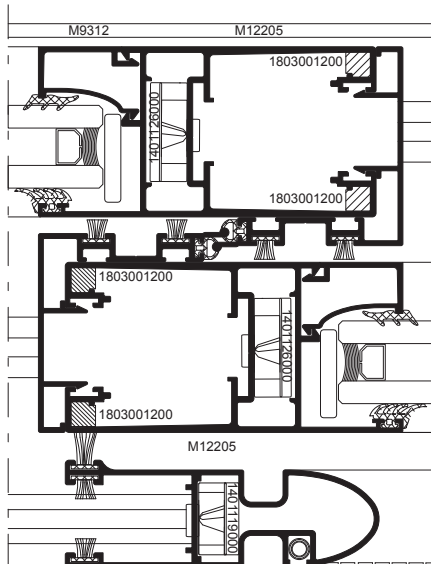

Section E

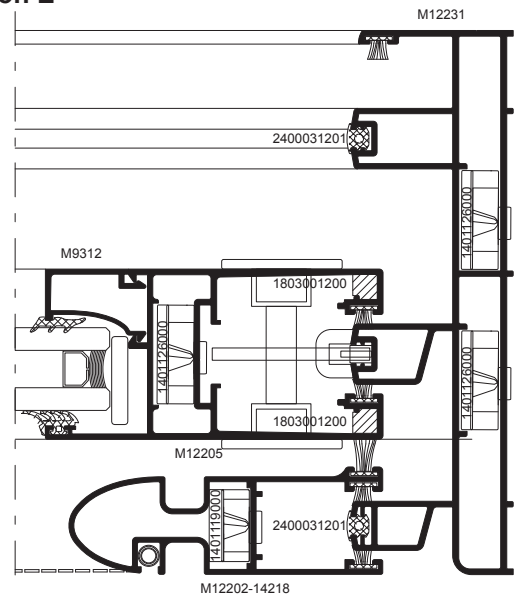

1)

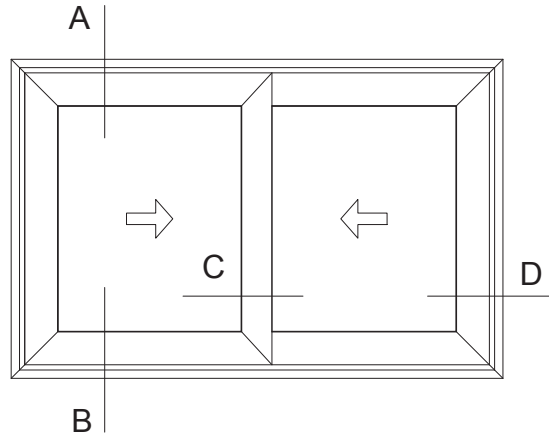

Section A

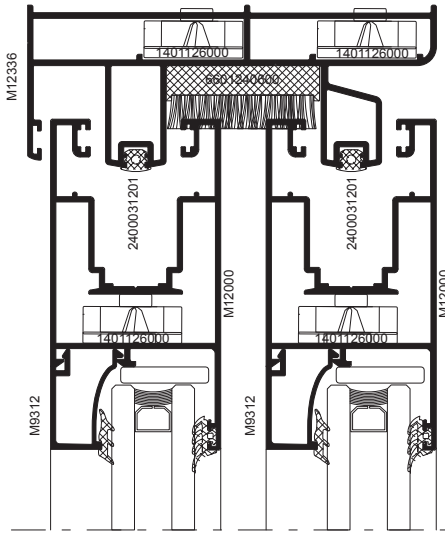

Section B

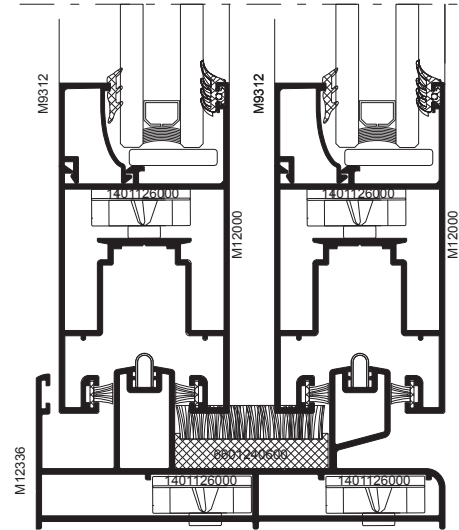

Section C

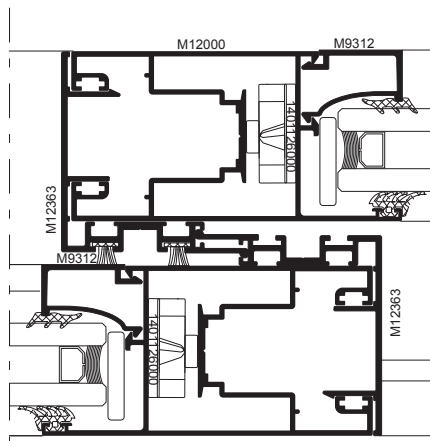

Section D

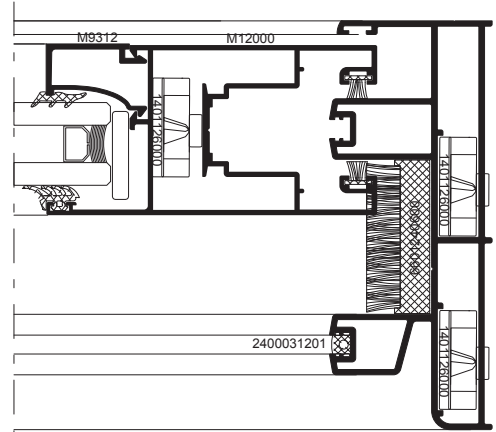

2)

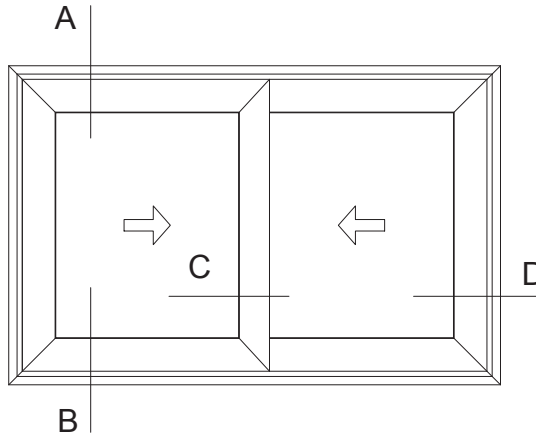

Section A

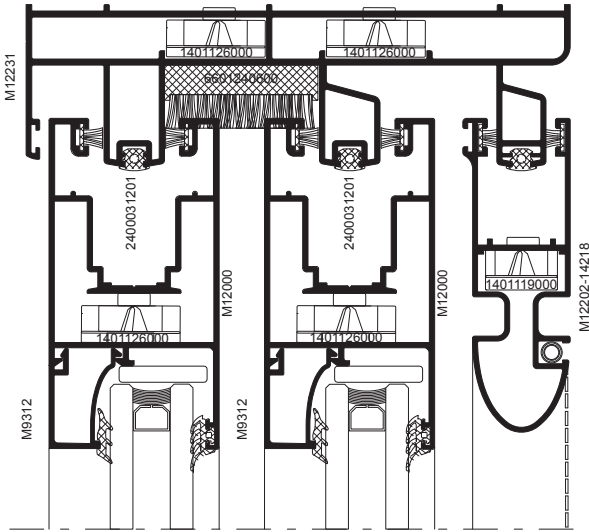

Section B

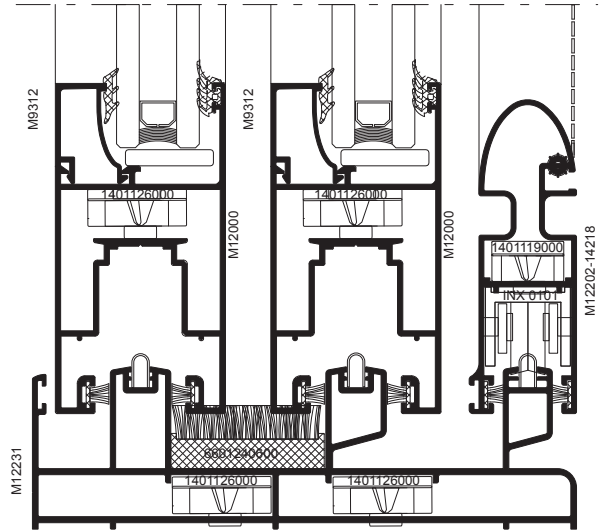

Section C

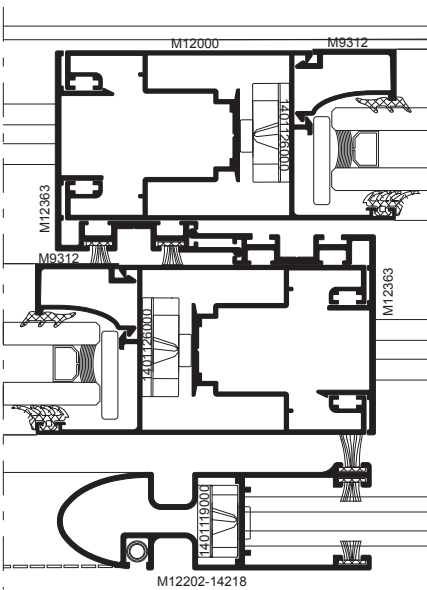

Section D

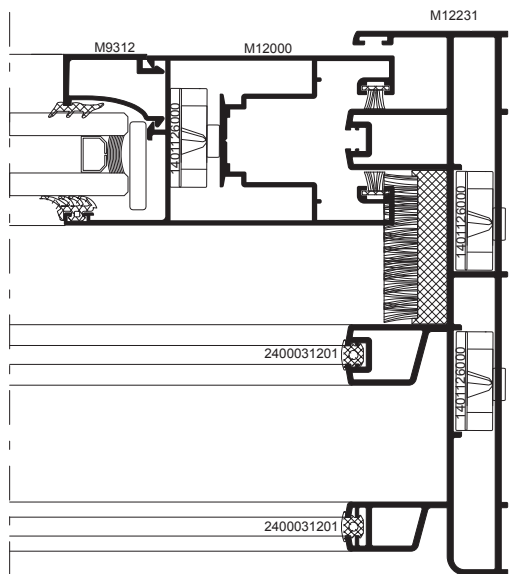

3)

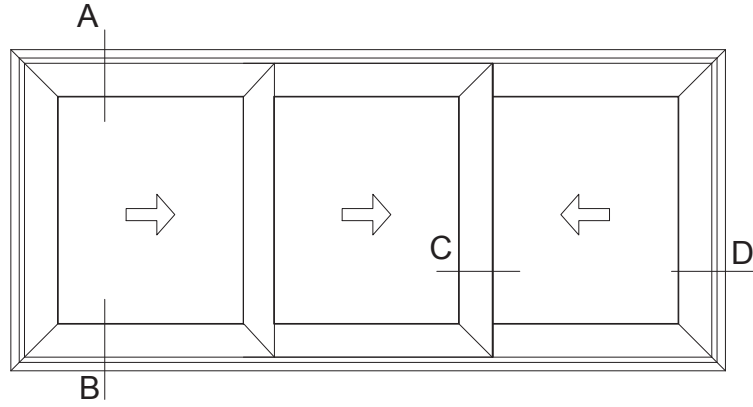

Section A

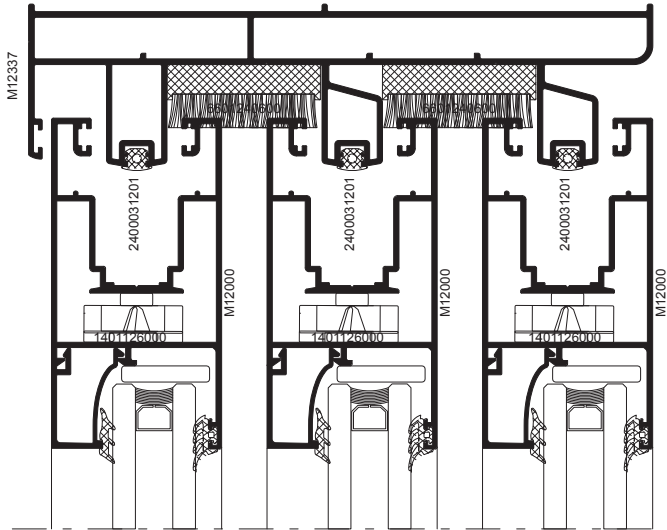

Section B

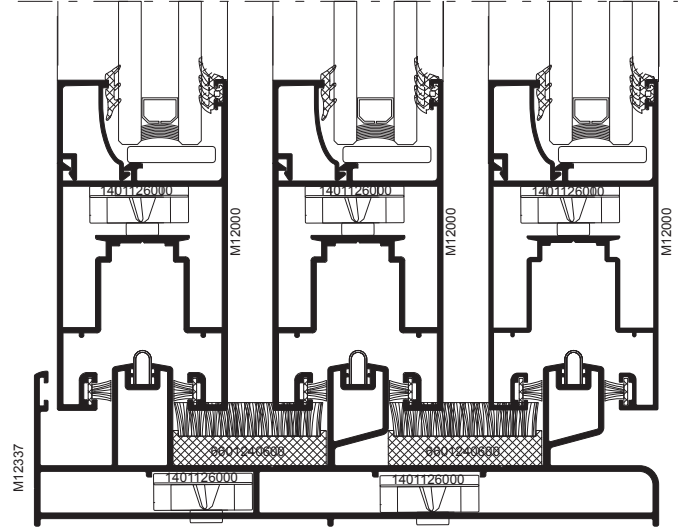

Section C

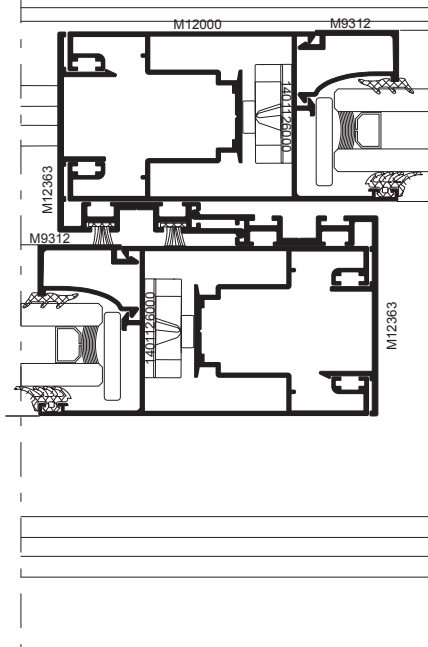

Section D

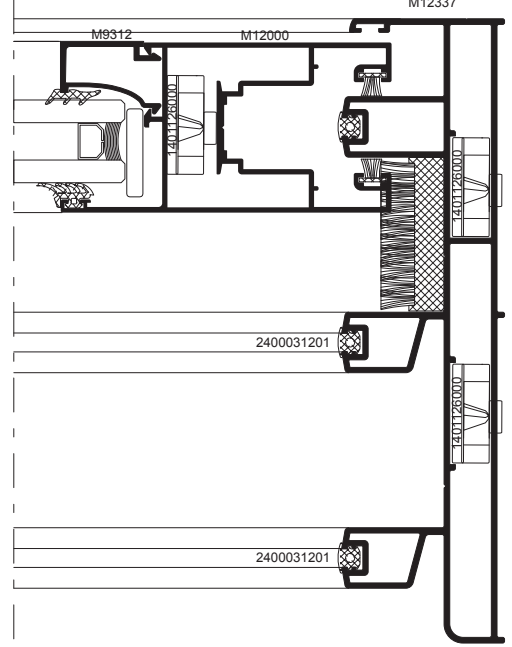

4)

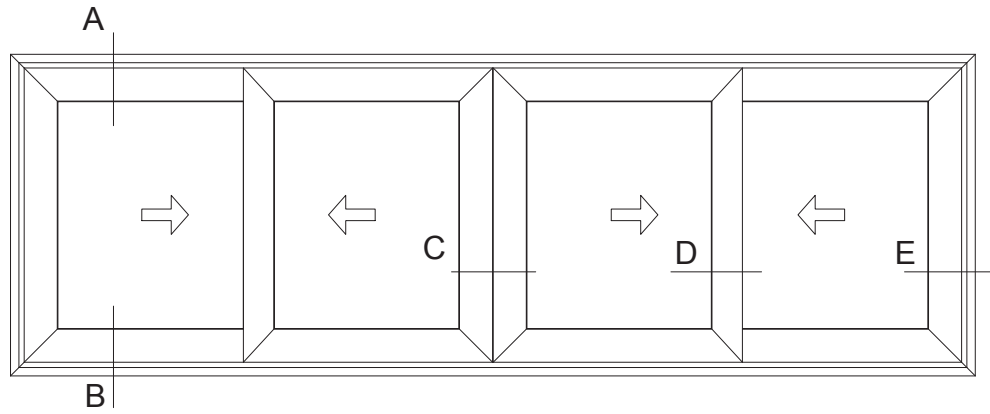

Section A

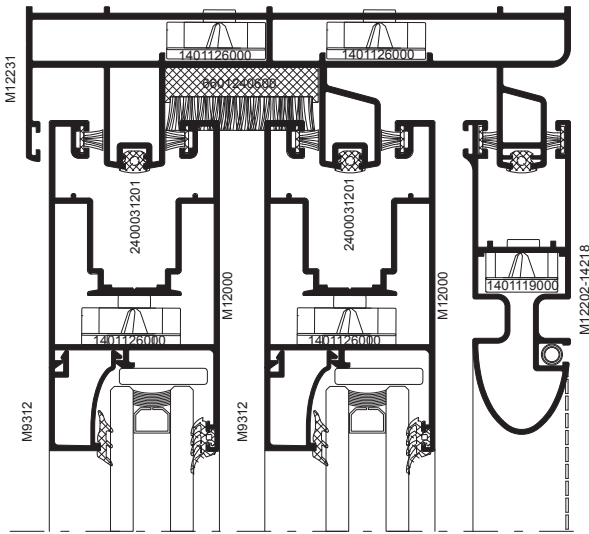

Section B

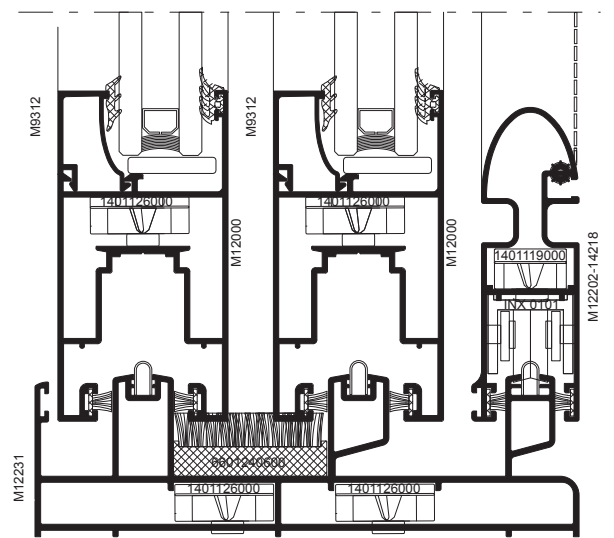

Section C

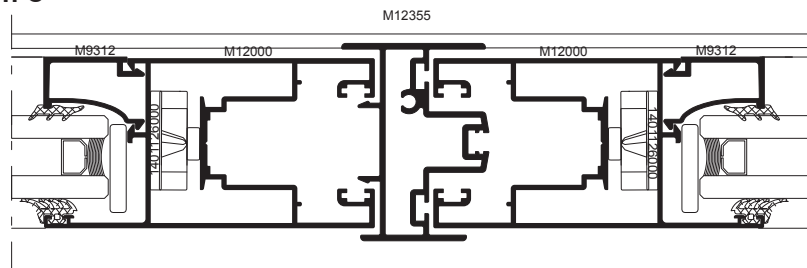

Section D

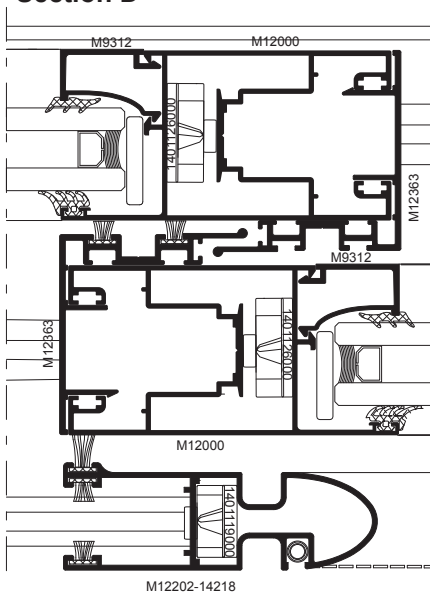

Section E

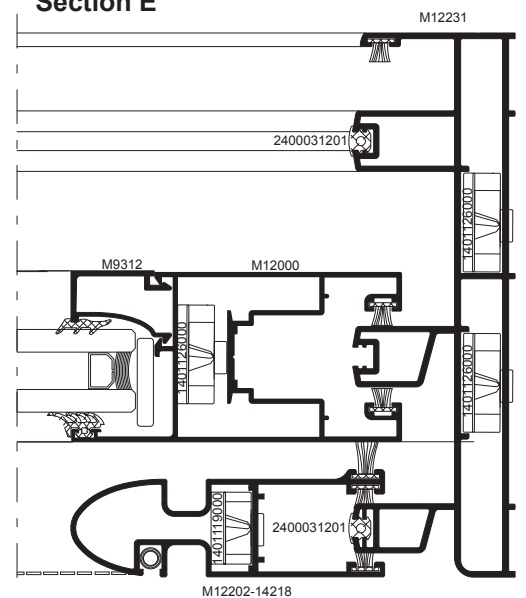

1)

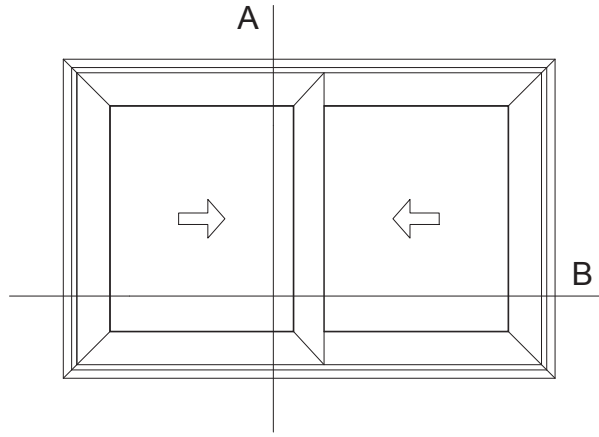

PROFILES CUTTING - 2SASH	
Sash Width	$S_w = (A+99mm) / 2$
Sash Width	$S_w = (F_w + 13mm) / 2$
Sash Height	$S_h = B + 17mm$
Sash Height	$S_h = F_h - 69mm$

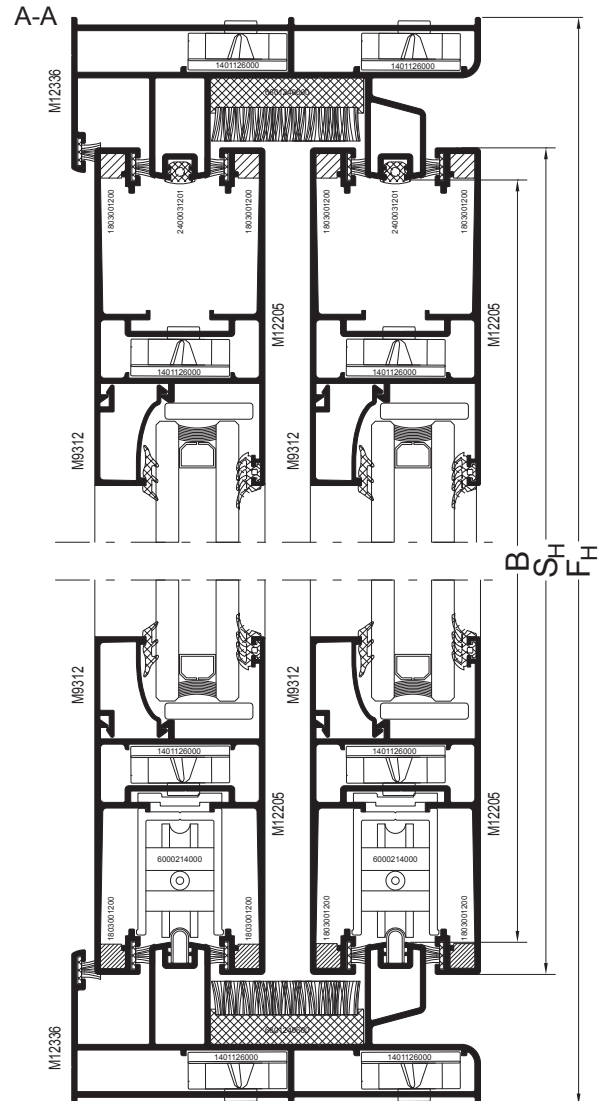
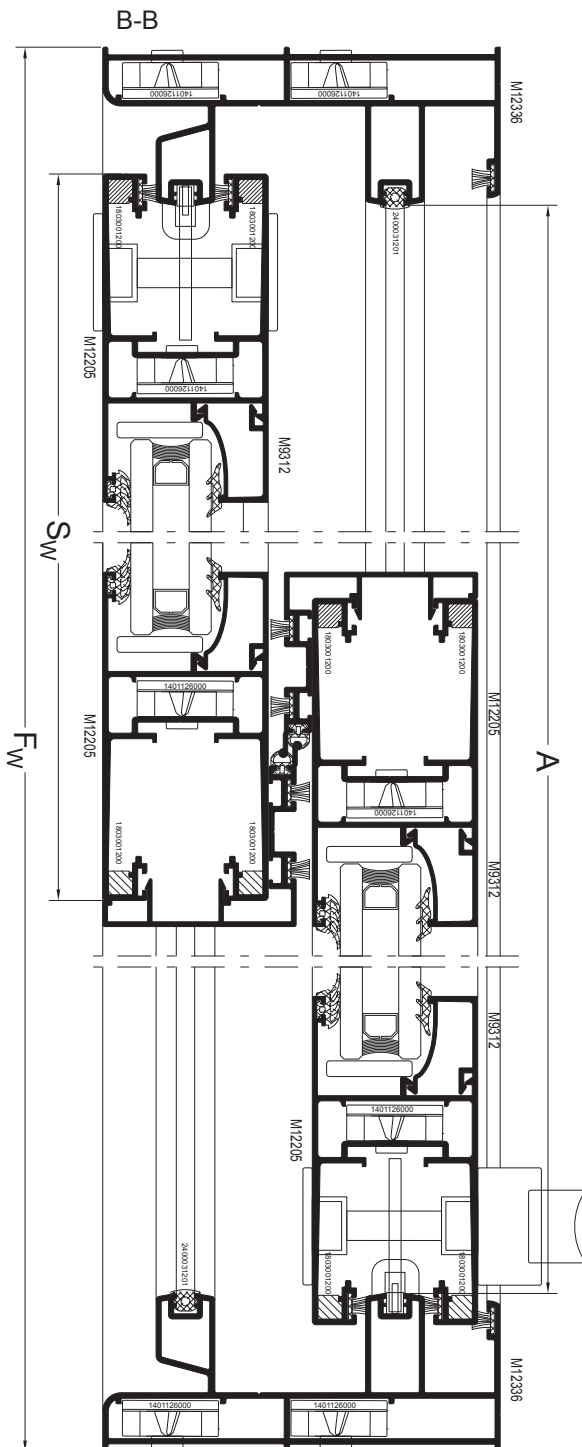

2)

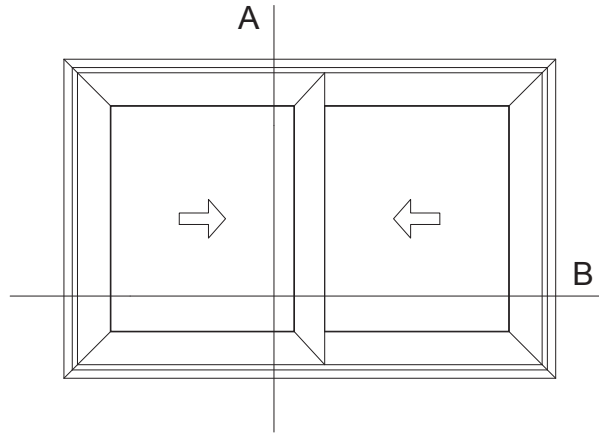

PROFILES CUTTING - 2SASH	
Sash Width	$S_W = (A + 99\text{mm}) / 2$
Sash Width	$S_W = (F_W + 13\text{mm}) / 2$
Sash Height	$S_H = B + 17\text{mm}$
Sash Height	$S_H = F_H - 69\text{mm}$

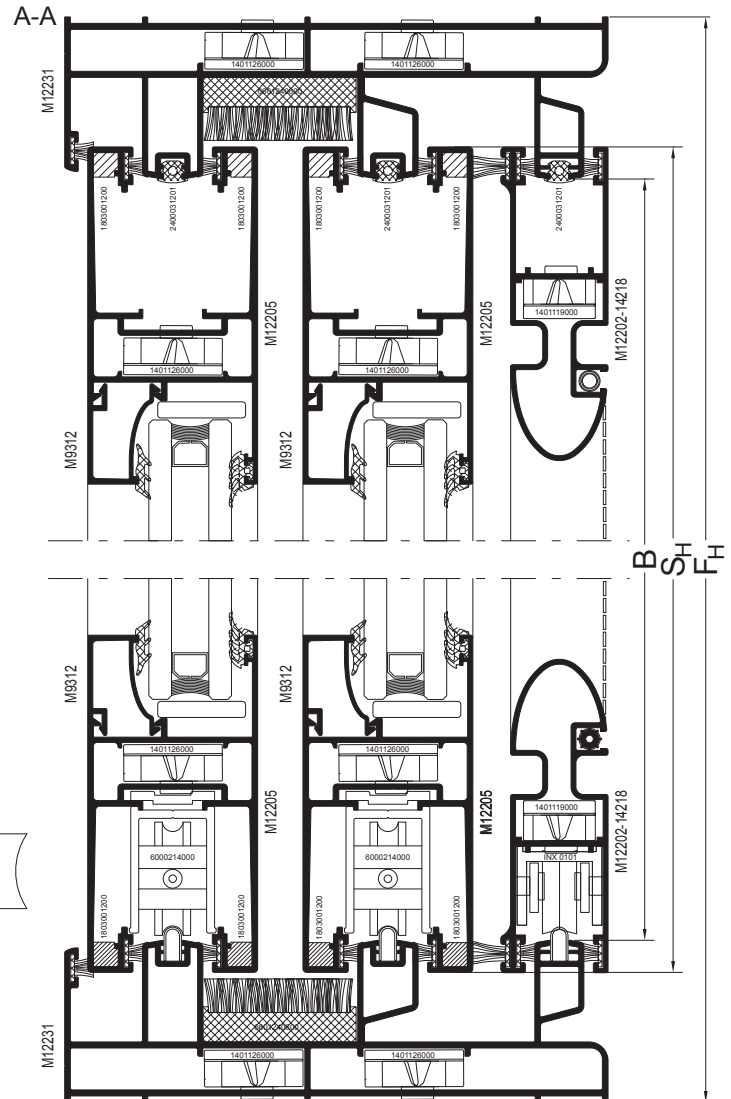
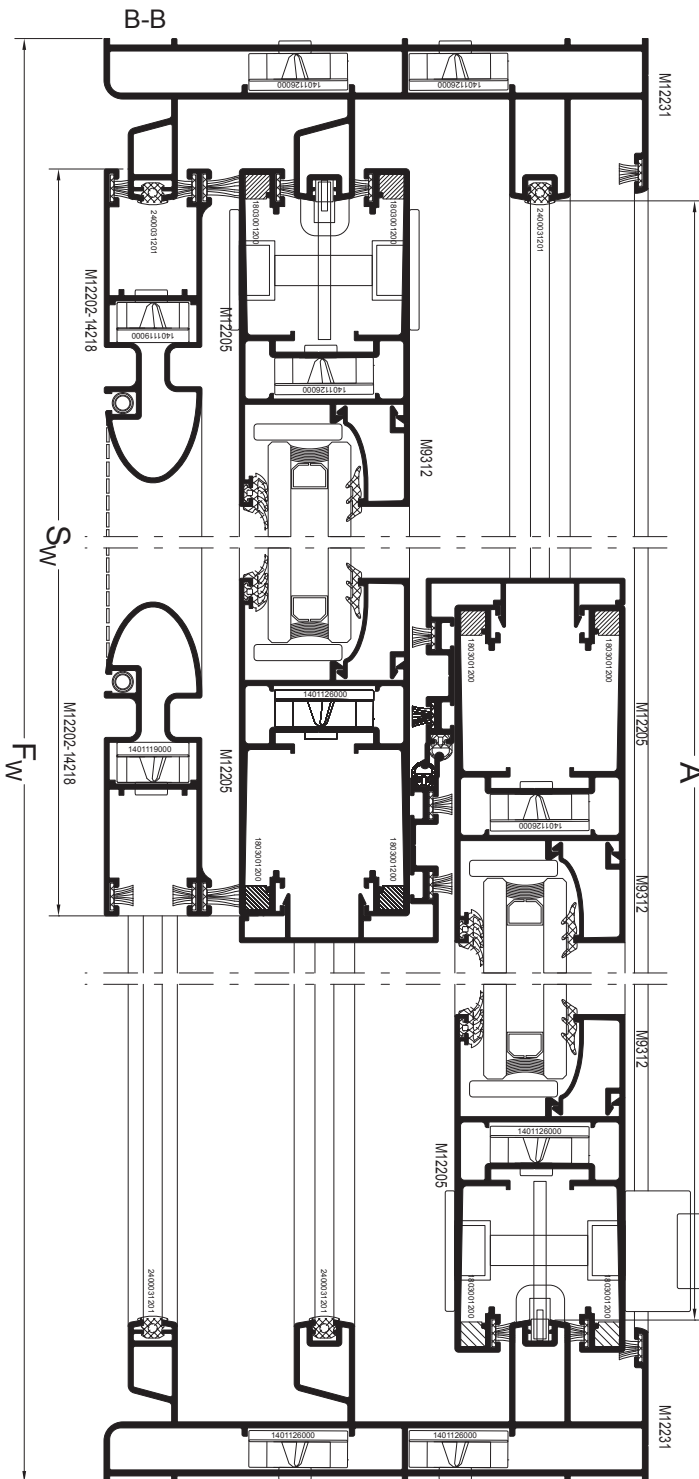

3)

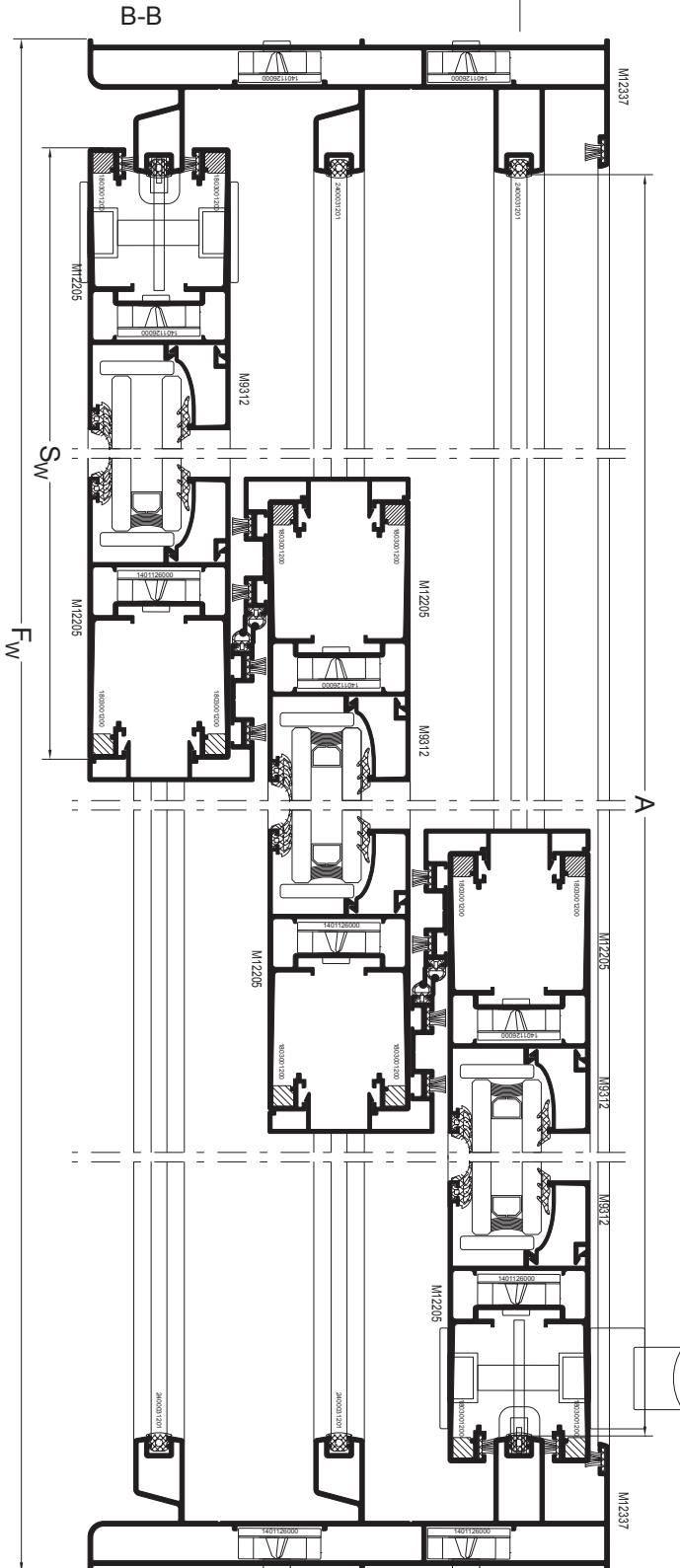
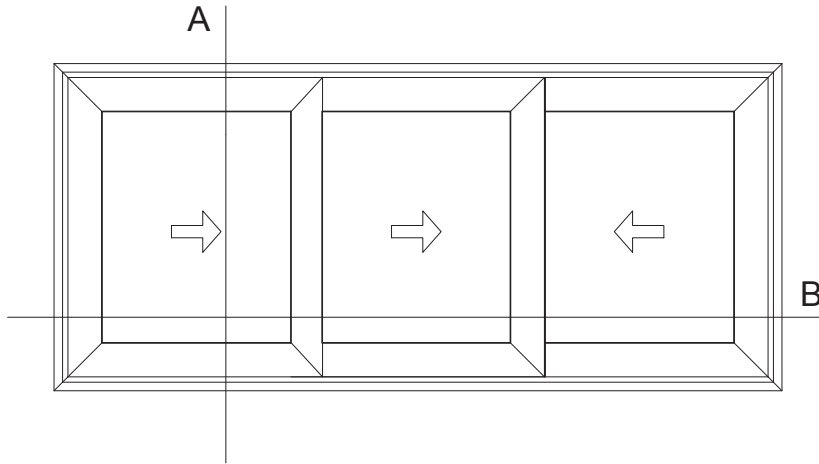

PROFILES CUTTING - 2SASH	
Sash Width	$S_w = (A + 181\text{mm}) / 2$
Sash Width	$S_w = (F_w + 95\text{mm}) / 2$
Sash Height	$S_H = B + 17\text{mm}$
Sash Height	$S_H = F_H - 69\text{mm}$

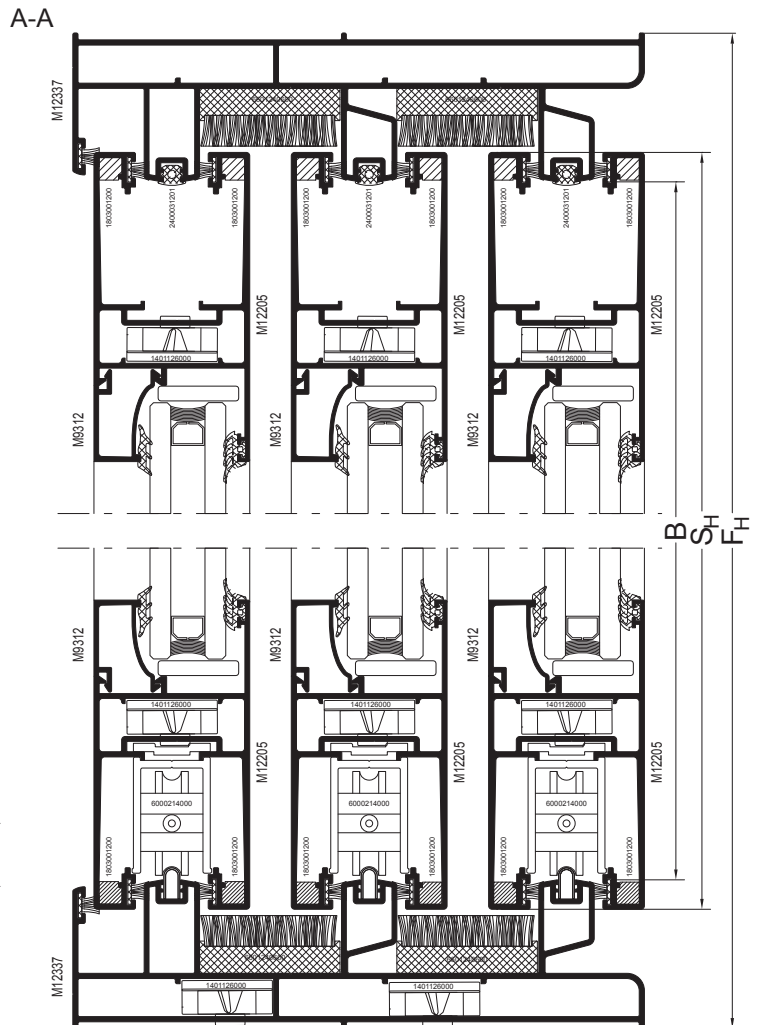

4)

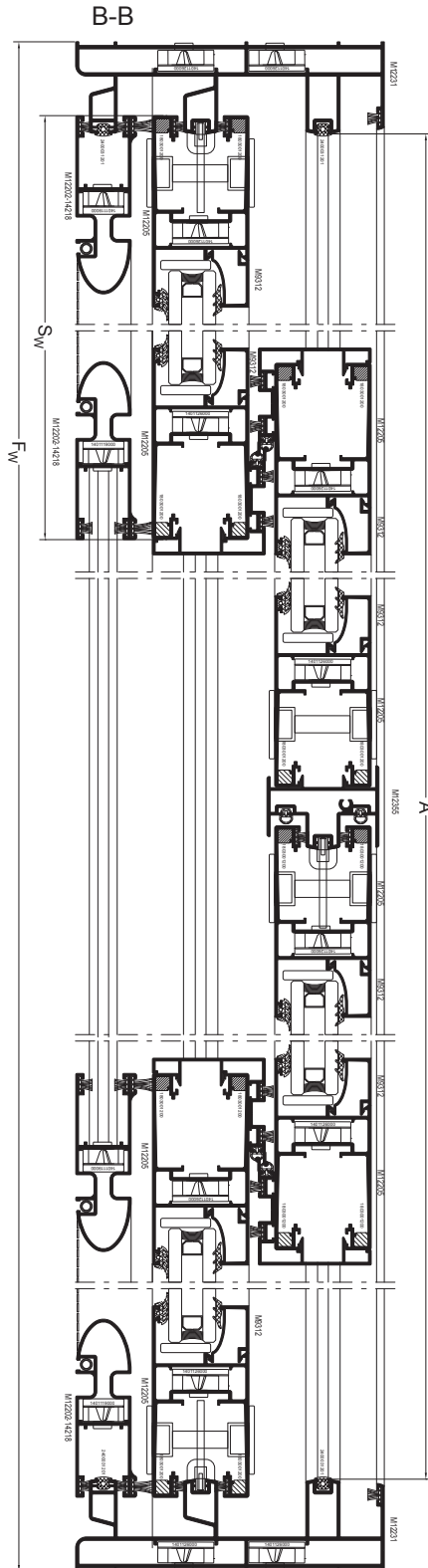
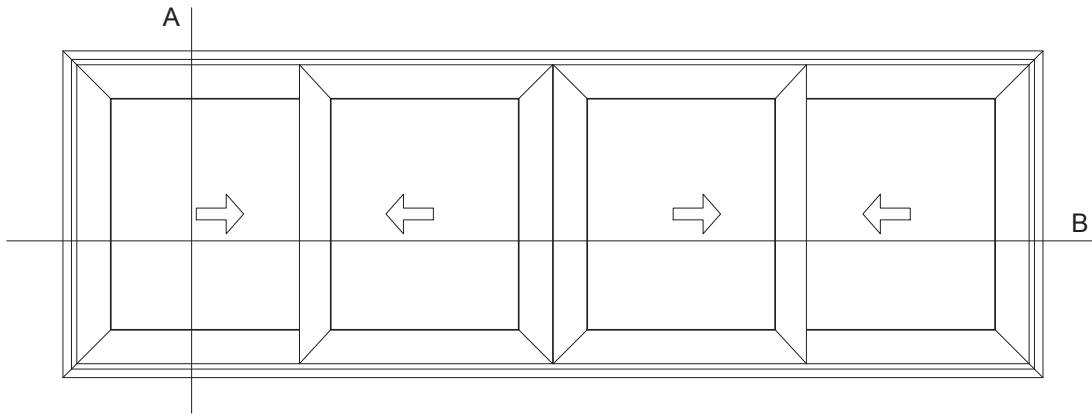

PROFILES CUTTING - 2SASH	
Sash Width	$S_W = (A + 163\text{mm}) / 2$
Sash Width	$S_W = (F_W + 77\text{mm}) / 2$
Sash Height	$S_H = B + 17\text{mm}$
Sash Height	$S_H = F_H - 69\text{mm}$

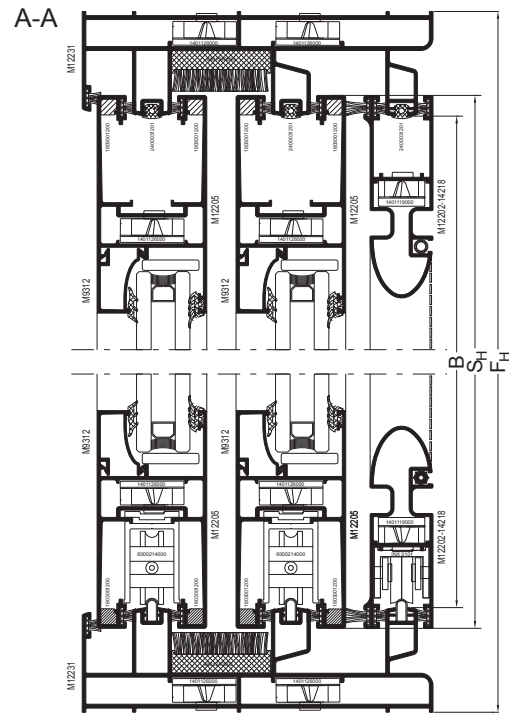

1)

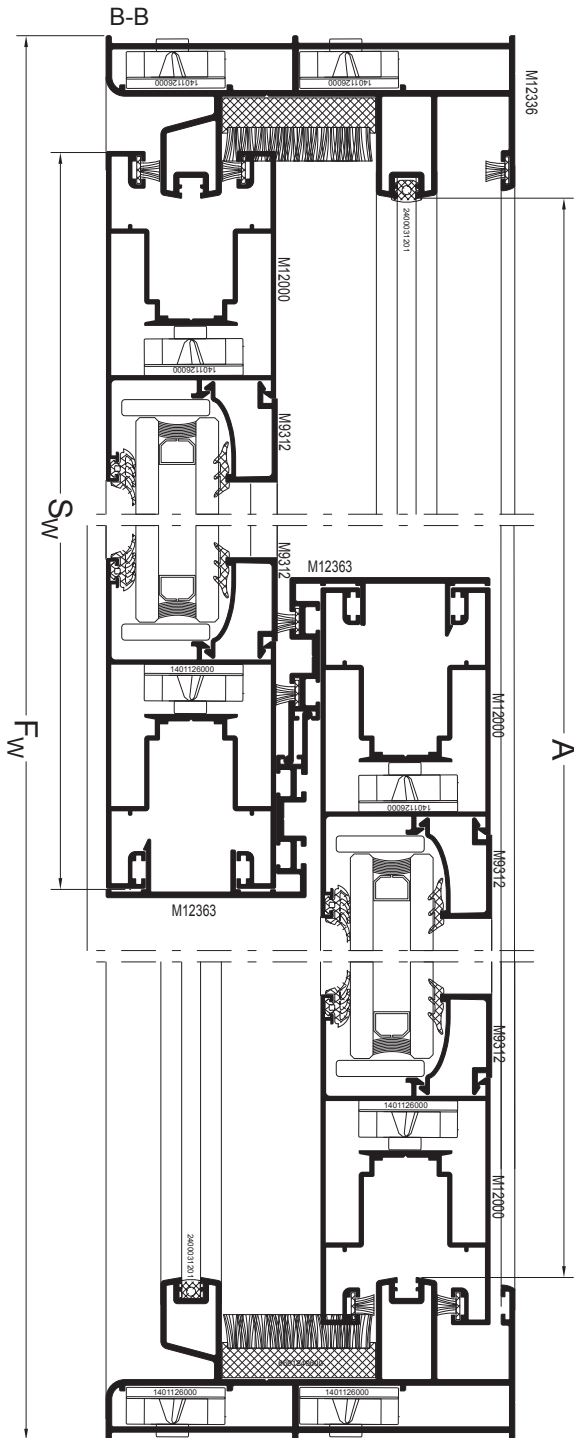
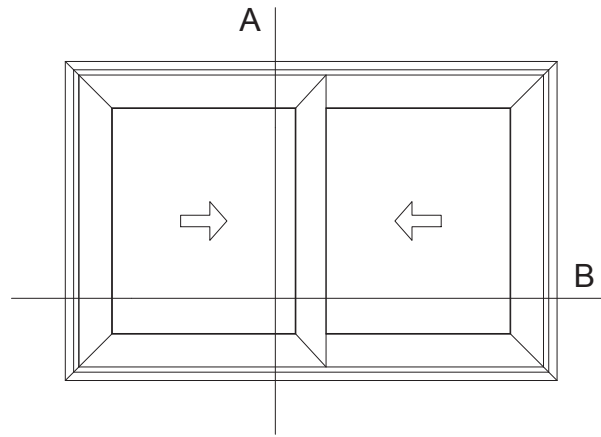

PROFILES CUTTING - 2SASH	
Sash Width	$S_w = (A + 99\text{mm}) / 2$
Sash Width	$S_w = (F_w + 13\text{mm}) / 2$
Sash Height	$S_h = B + 17\text{mm}$
Sash Height	$S_h = F_h - 69\text{mm}$

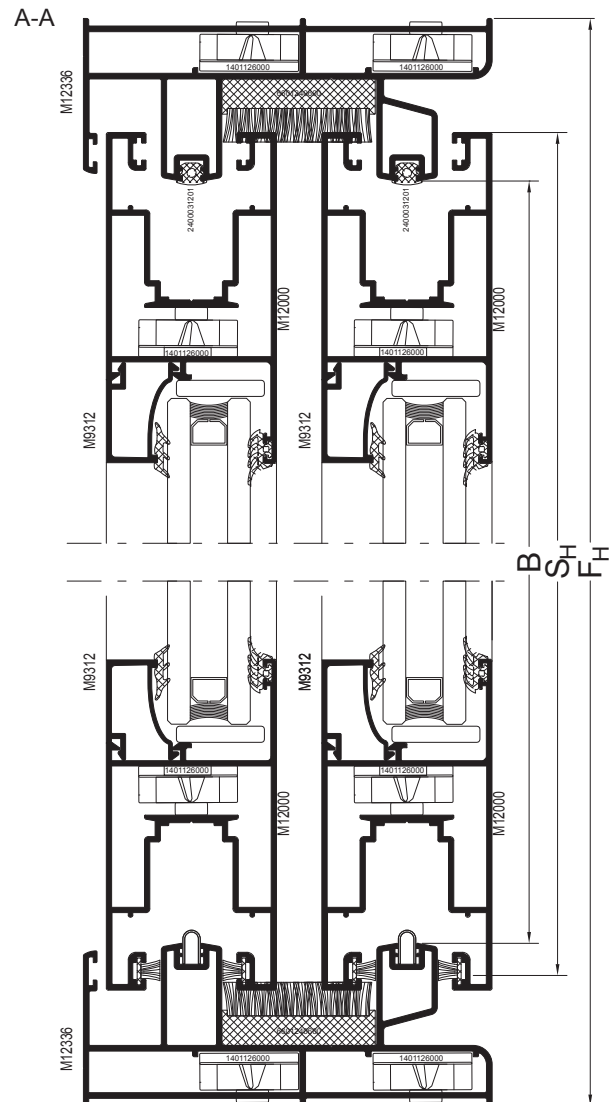

2)

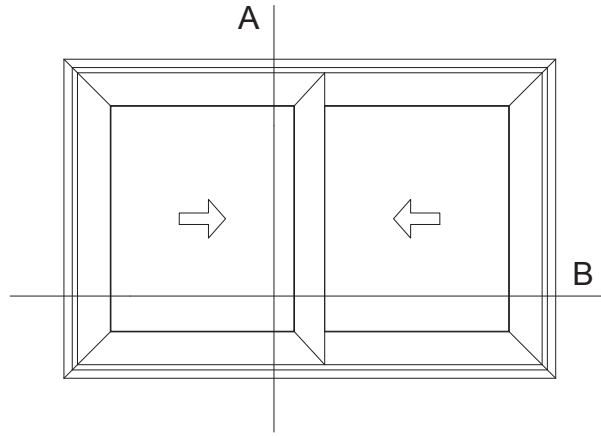

PROFILES CUTTING - 2SASH	
Sash Width	$S_w = (A+99mm) / 2$
Sash Width	$S_w = (F_w+13mm) / 2$
Sash Height	$S_H = B+17mm$
Sash Height	$S_H = F_H -69mm$

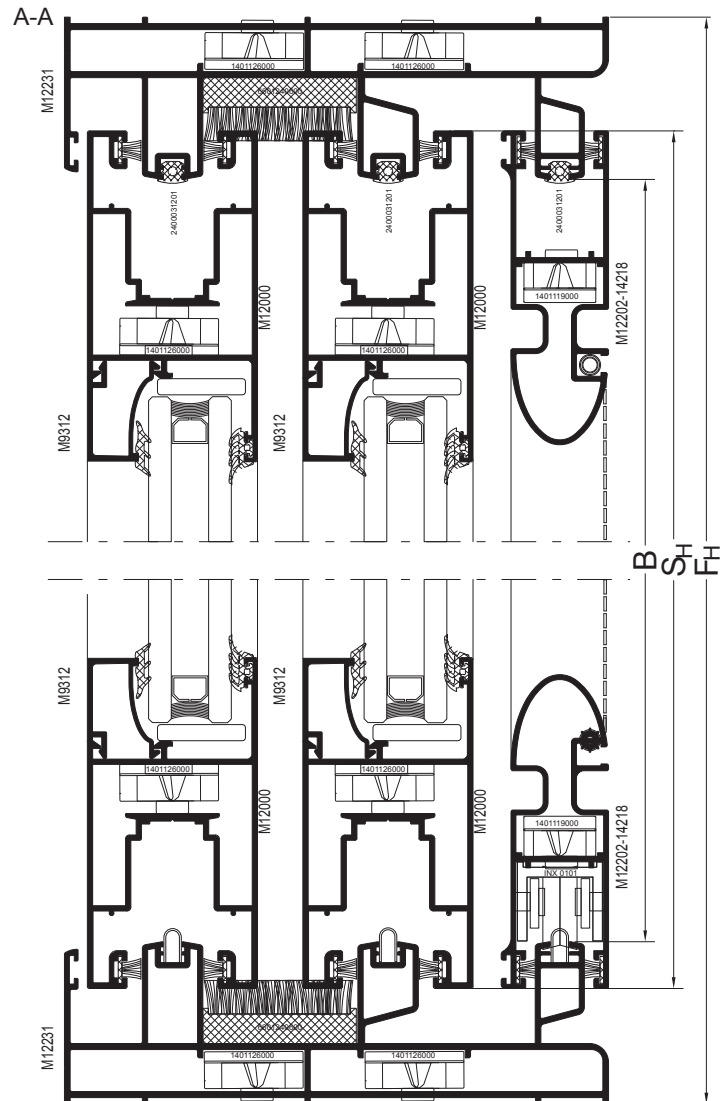
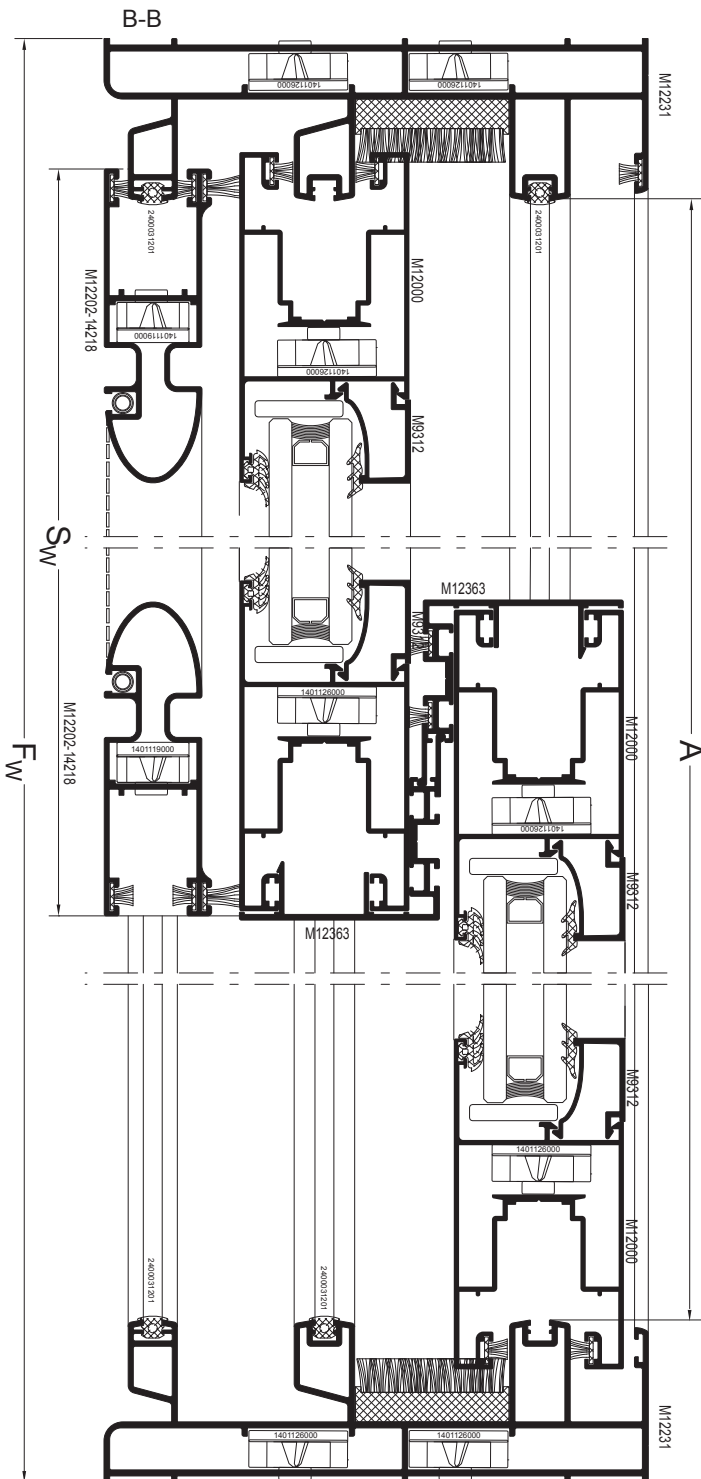

3)

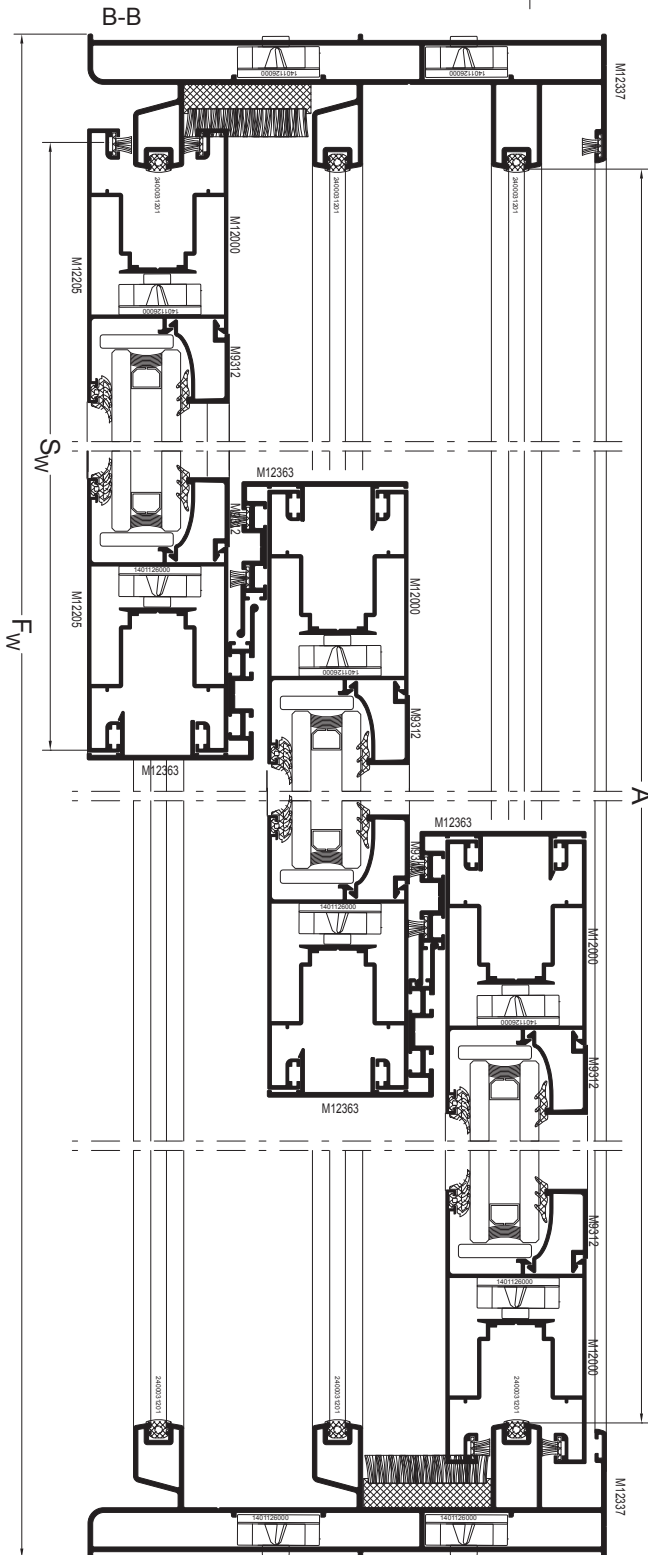
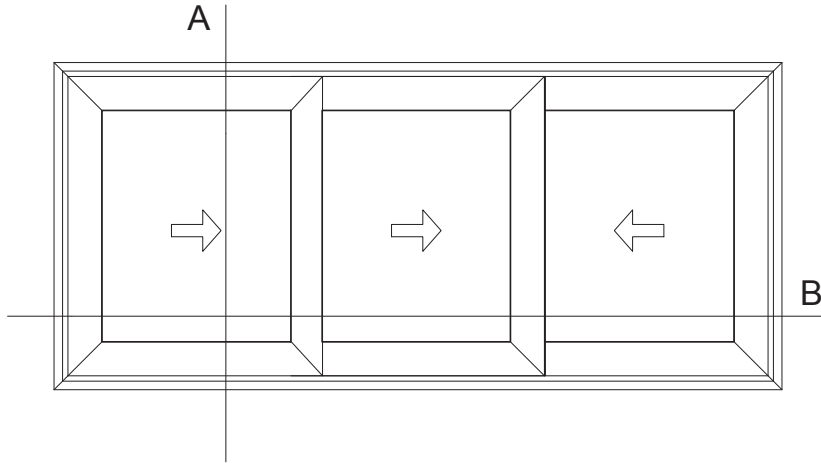

PROFILES CUTTING - 2SASH	
Sash Width	$S_w = (A+181mm) / 2$
Sash Width	$S_w = (F_w + 95mm) / 2$
Sash Height	$S_H = B + 17mm$
Sash Height	$S_H = F_H - 69mm$

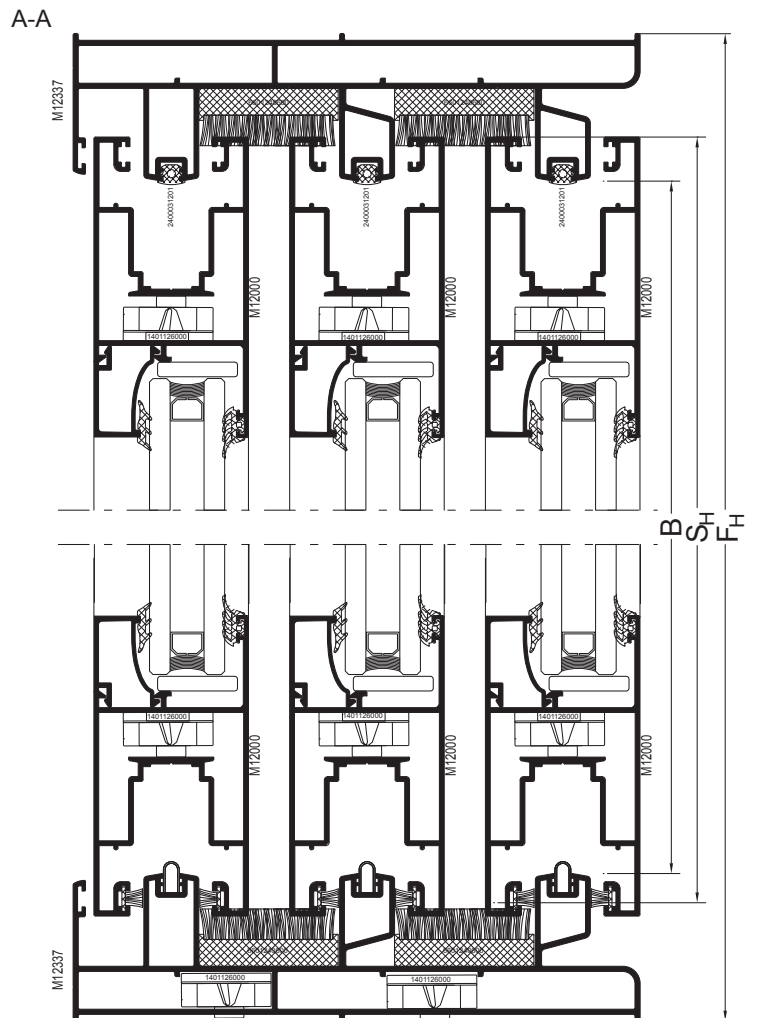

4)

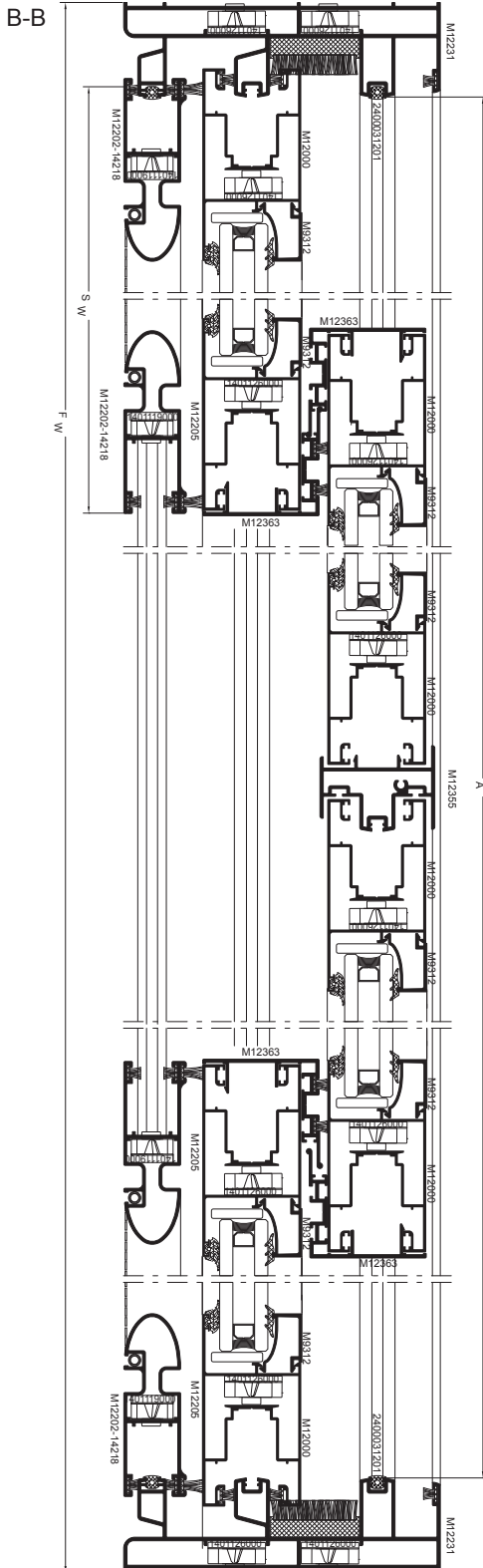
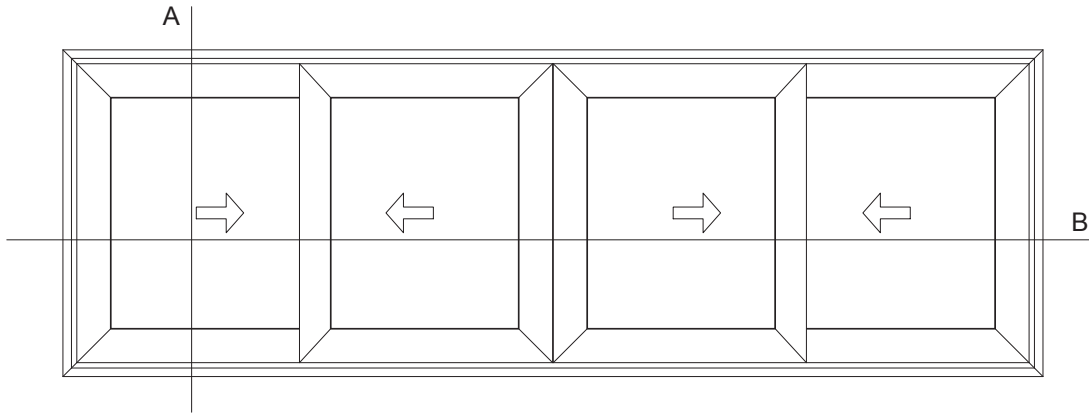

PROFILES CUTTING - 2SASH	
Sash Width	$S_w = (A + 163\text{mm}) / 2$
Sash Width	$S_w = (F_w + 77\text{mm}) / 2$
Sash Height	$S_H = B + 17\text{mm}$
Sash Height	$S_H = F_H - 69\text{mm}$

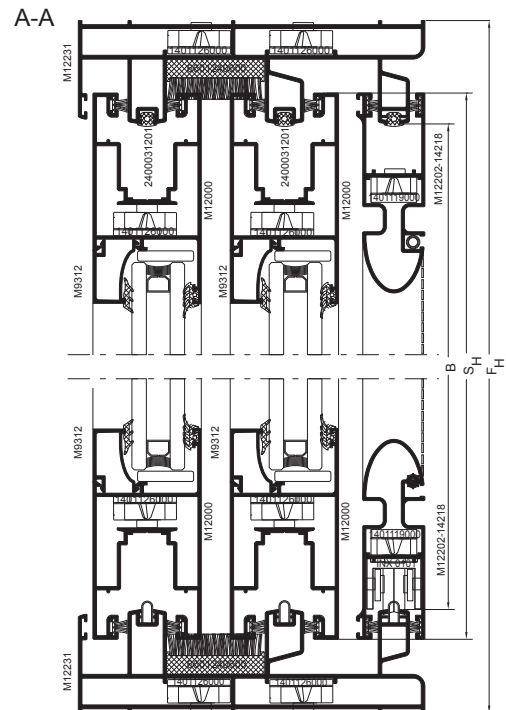

140-11-190-00

Cast aluminum Piece



Cast spring cleat

140-11-260-00

Cast aluminum Piece



Cast spring cleat

660-12-140-00

Aluminum Bar 6m



Stainless steel guide

180-19-000-00

Steel Piece



Alignment corner

650-12-012-00

Polyamide Piece



Shock absorber

650-14-218-00

Polyamide Piece



Fly-screen shock absorber

600-01-140-00

Aluminum Piece



Single roller

600-02-140-00

Aluminum Piece



Double roller

600-01-201-00

Aluminum Piece



Fly-screen roller

240-00-312-01

EPDM Meters



Frame guide gasket

250-07-310-33

PVC Meters

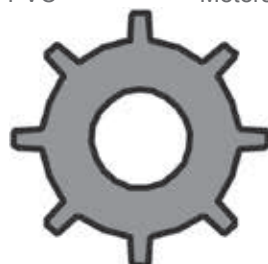

Fly-Screen gasket